

SPARE PARTS LIST

Electric Pallet Truck PTE20B

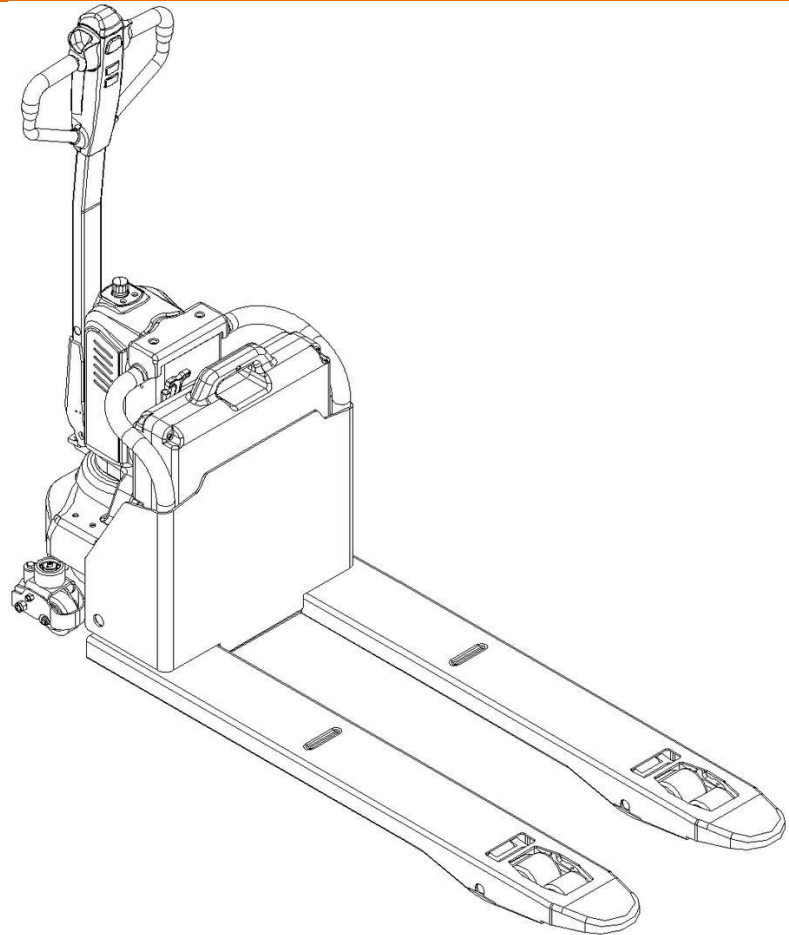

Version 12/2019

From truck identification number:

PTE20B -BPT-002-EN

Catalogue

Fig. 1 Chassis (540x1150)	3
Fig. 2 Chassis (685x1150)	5
Fig. 3 Load roller components	7
Fig. 4 Driving unit.....	9
Fig. 5 Driving wheel components	11
Fig. 6 Cylinder.....	12
Fig. 7 Power unit.....	14
Fig. 8 Hydraulic components	16
Fig. 9 Steering wheel components (with side rollers).....	17
Fig. 10 Tiller head	18
Fig. 11 Tiller arm components.....	20
Fig. 12 Truck components	21
Fig.13 Power supply assembly.....	23
Fig. 14 Controller components	24
Fig. 15 Power supply control components	25
Fig. 16 Charger.....	26
Fig. 17 Wiring harness.....	27
Fig. 18 Sticker (EU).....	28
Fig. 19 Sticker (US).....	29
Easy worn parts list.....	30

Fig. 1 Chassis (540x1150)

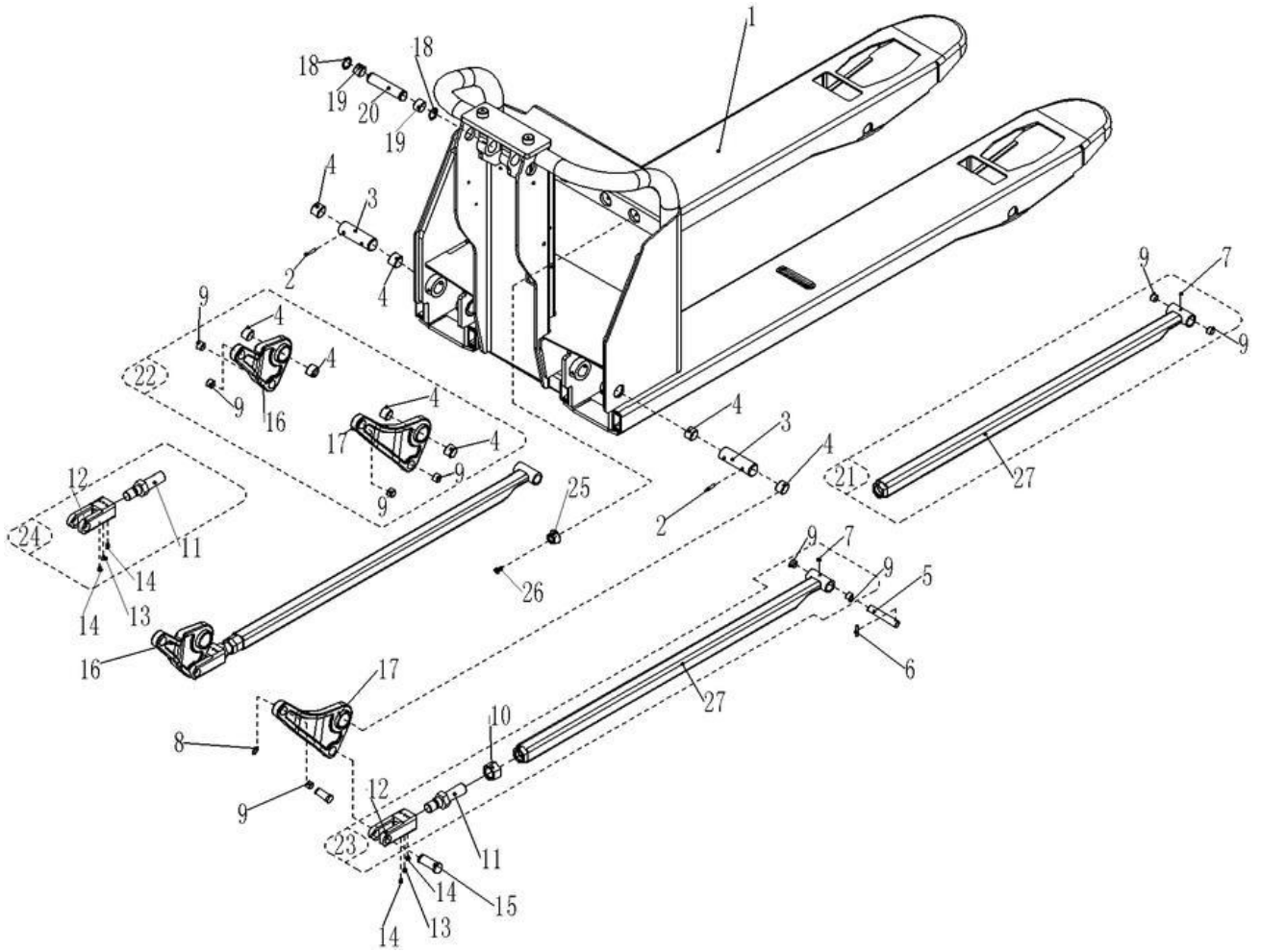

Fig. 1 Chassis (540x1150)

No.	Art No.	Description	Qty.	Note
1	508638510000	Chassis welding (540x1150)	1	
2	910600400041	Cylindrical pin	2	6x40
3	508638520017	Axle	2	Φ 24.6x119
4	940500100097	Bushing Φ 24.6xΦ 29x25	4	With grease storage holes
5	502338520030	Push rod Axle	2	Φ 16x82
6	910600400024	Cylindrical pin	2	5x28
7	911200100001	Grease nipple	2	6
8	910401300007	Circlip	4	16
9	940500100083	Bushing Φ 16xΦ 18x15	8	With grease storage holes
10	910300400008	Nut	2	M20x1.5
11	508038520029	Bolt	2	
12	508038520028	Push rod fork	2	
13	910201000005	Screw	2	M6x8
14	910600400015	Cylindrical pin	4	4x30
15	508038520041	Axle	4	Φ 16x44
16	508638510001	Rock arm welding	1	Left
17	508638510002	Rock arm welding	1	Right
18	910401300011	Circlip	2	20
19	940500100096	Bushing Φ 20xΦ 23x22	2	With grease storage holes
20	508538520016	Axle	1	Φ 20x92
21	508698510000	Push rod components (1150)	2	1150
22	508698510001	Rock arm components	1	540
23	508698510002	Push rod kits (1150)	2	1150
24	508598510014	Push rod fork components	2	
25	502038520029	Limitter	4	
26	910200600023	Screw	4	M6x12
27	508638510003	Push rod welding	2	1150

Fig. 2 Chassis (685x1150)

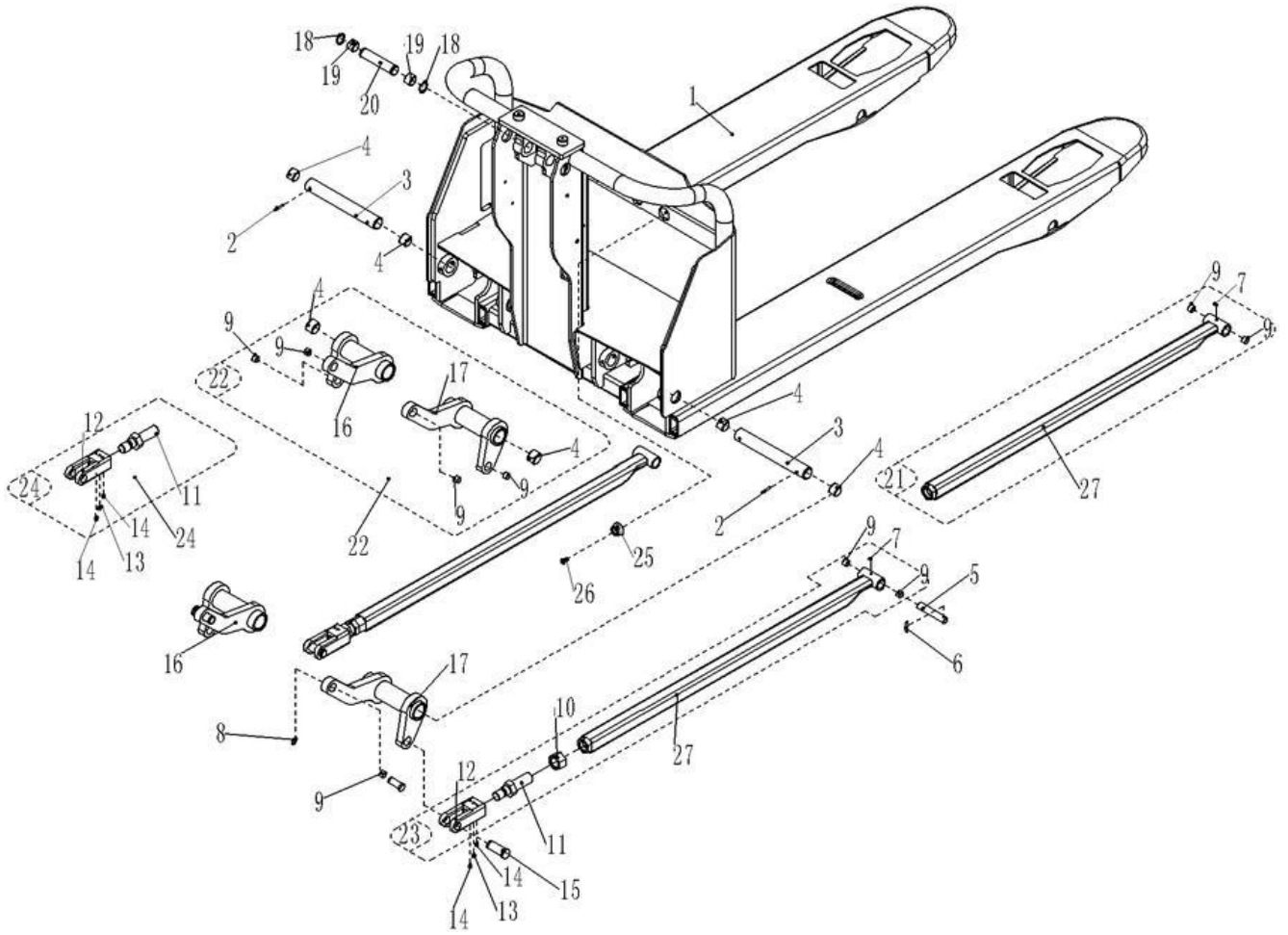

Fig. 2 Chassis (685x1150)

No.	Art No.	Description	Qty.	Note
1	508638510001	Chassis welding (685x1150)	1	
2	910600400041	Cylindrical pin	2	6x40
3	508638520030	Axle	2	Φ 24.6x200
4	940500100097	Bushing Φ 24.6xΦ 29x25	4	With grease storage holes
5	502338520030	Push rod Axle	2	Φ 16x82
6	910600400024	Cylindrical pin	2	5x28
7	911200100001	Grease nipple	2	6
8	910401300007	Circlip	4	16
9	940500100083	Bushing Φ 16xΦ 18x15	8	With grease storage holes
10	910300400008	Nut	2	M20x1.5
11	508038520029	Bolt	2	
12	508038520028	Push rod fork	2	
13	910201000005	Screw	2	M6x8
14	910600400015	Cylindrical pin	4	4x30
15	508038520041	Axle	4	Φ 16x44
16	508638510005	Rock arm welding (685)	1	Left
17	508638510006	Rock arm welding (685)	1	Right
18	910401300011	Circlip	2	20
19	940500100096	Bushing Φ 20xΦ 23x22	2	With grease storage holes
20	508538520016	Axle	1	Φ 20x92
21	508698510000	Push rod components (1150)	2	1150
22	508698510003	Rock arm components	1	685
23	508698510002	Push rod kits (1150)	2	1150
24	508598510014	Push rod fork components	2	1150
25	502038520029	Limiters	4	
26	910200600023	Screw	4	M6x12
27	508638510003	Push rod welding	2	1150

Fig. 3 Load roller components

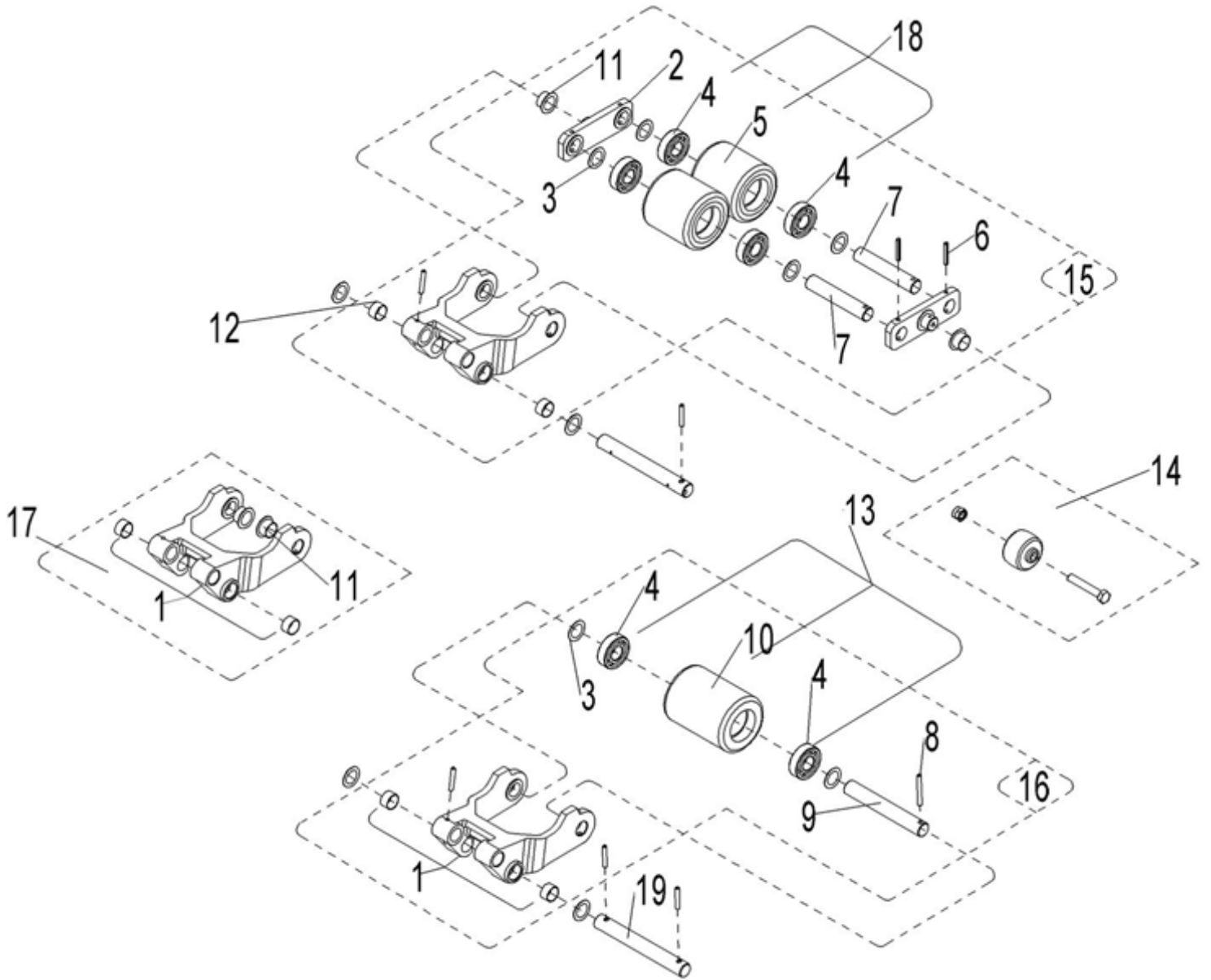

Fig. 3 Load Roller Components

No.	Art No.	Description	Qty.	Note
1	508098510048	Frame of roller components (Single)	2	
2	502317020000	Linking plate	4	Tandem
3	940600500013	Washer $\Phi 25 \times \Phi 20.5 \times 1$	8/4(Tandem/Single)	
4	910700200019	Bearing GB276-6204-2RS	8/4(Tandem/Single)	
5	940300300005	Roller $\Phi 80 \times 70$ (Steel core PU)	4(Tandem)	
6	910600400027	Cylindrical pin GB879.1-5x35	8(Tandem)	
7	502317020001	Wheel axle $\Phi 20 \times 94$	4(Tandem)	
8	910600400027	Cylindrical pin GB879.1-5x35	8(Tandem)	
9	301017020001	Wheel axle $\Phi 20 \times 122$	2(Single)	
10	940300300023	Roller $\Phi 80 \times 93$ (Steel core PU)	2(Single)	
11	940500200038	Bushing (With shoulder) $\Phi 18 \times \Phi 20 \times 12$	4 (Tandem)	With grease storage holes
12	940500100088	Bushing $\Phi 20 \times \Phi 22 \times 12$	4	With grease storage holes
13	502398510014	Wheel set kits (Single)	2	
14	502398510003	Entry roller kits	2	
15	508098510049	Roller kits (Tandem)	2	
16	508098510050	Roller kits (Single)	2	
17	508098510051	Frame of roller components (Tandem)	2	
18	502398510002	Wheel set kits (Tandem)	4	
19	508038520030	Axle $\Phi 20 \times 158$	2	

Fig. 4 Driving unit

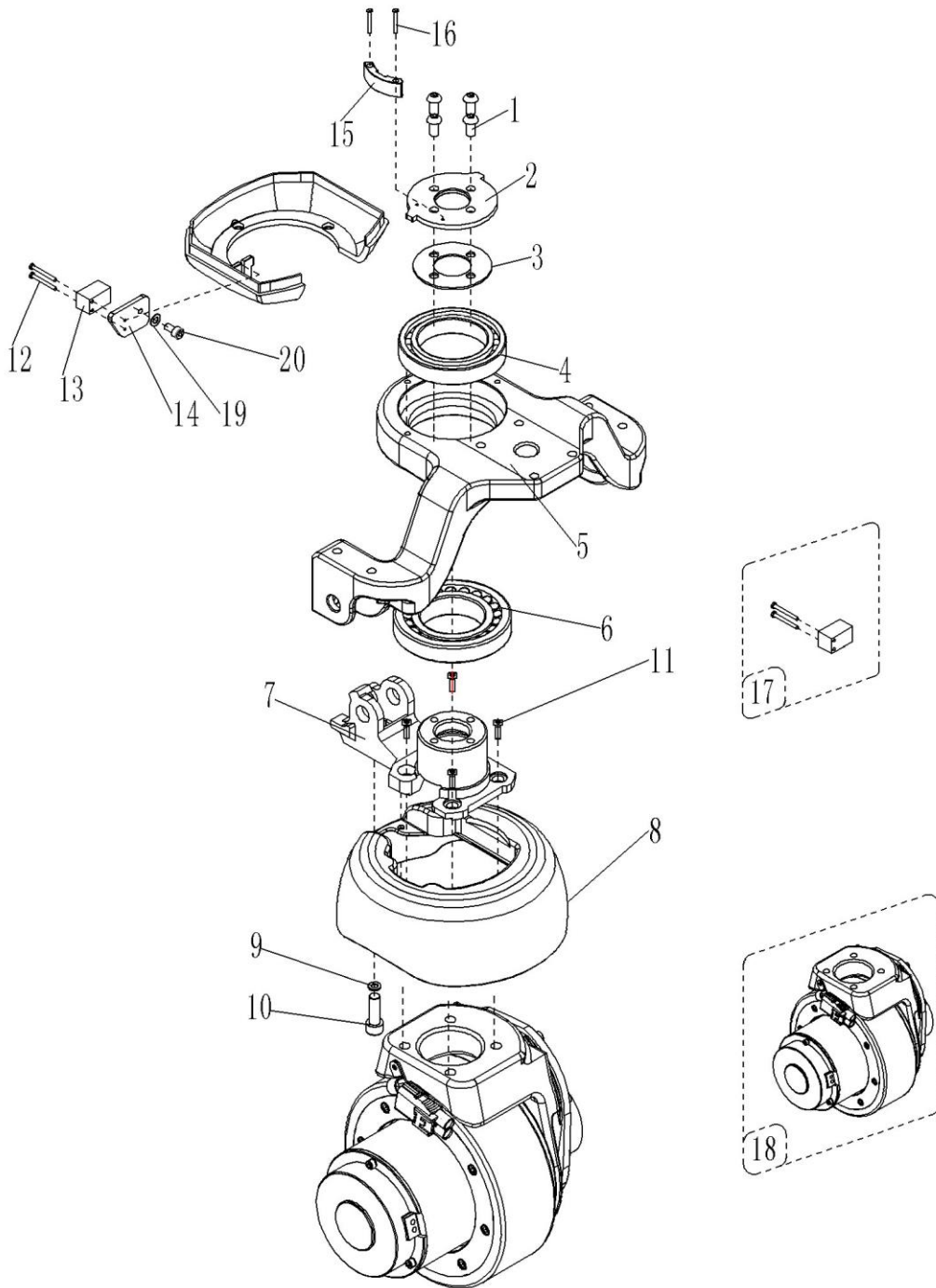

Fig. 4 Driving Unit

No.	Art No.	Description	Qty	Note
1	910200300024	Screw	4	M8x16
2	508513520002	Bearing cap	1	
3	508013520004	Washer	1	
4	910700200058	Bearing	1	6013
5	508513520001	Driving wheel seat	1	
6	910700600044	Bearing	1	32913
7	508513520000	Linking flange	1	
8	508013520101	Round cover	1	
9	910400100005	Washer	2	6
10	910200200032	Screw	2	M6x10
11	910200200076	Screw	4	M10x25
12	910200200007	Screw M3x25	2	With speed reduction on curve
13	920200400025	Proximity switch AZ17M05PB30	1	With speed reduction on curve
14	508533020001	Mounting plate (Sensor)	1	With speed reduction on curve
15	508533020000	Sensor block	1	With speed reduction on curve
16	910200500015	Screw M3x20	2	With speed reduction on curve
17	508598510002	Proximity switch components	1	With speed reduction on curve
18	508598510003	Driving components	1	
19	910400100003	Washer	1	4
20	910200300005	Screw	1	M4x8

Fig. 5 Driving wheel components

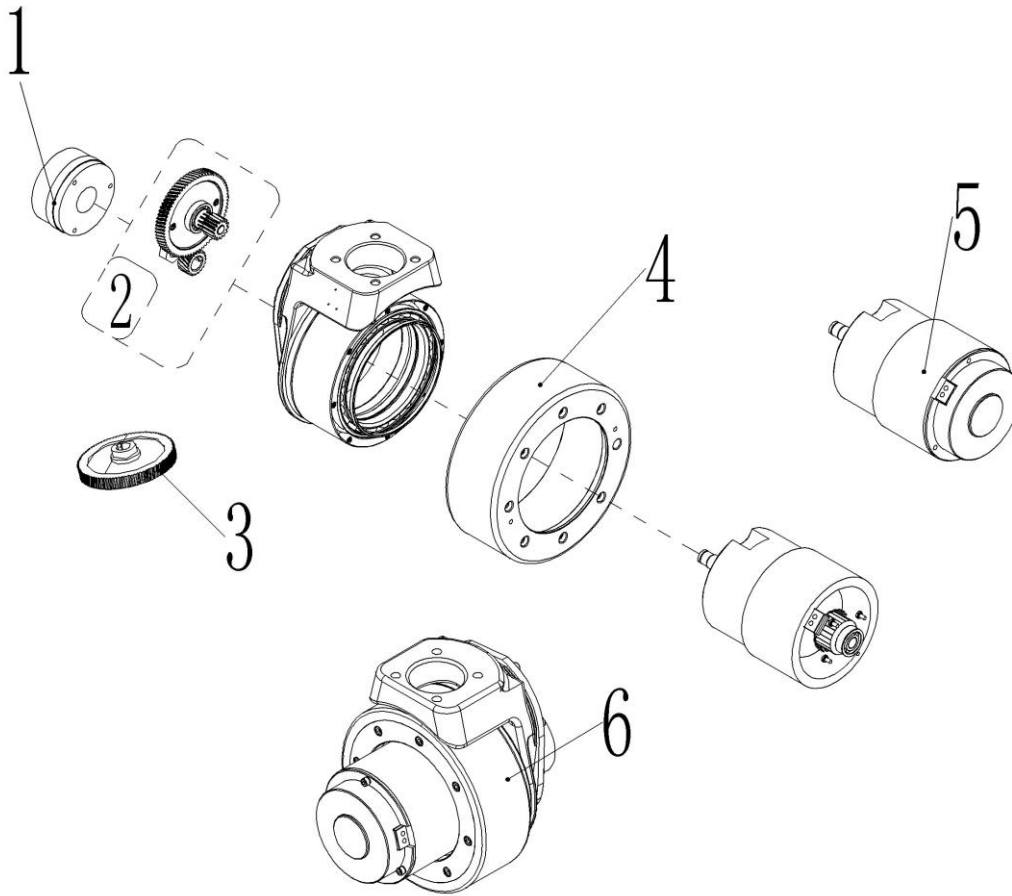

Fig. 5 Driving Wheel Components

No.	Art No.	Description	Qty.	Note
1	508533010010	Brake	1	
2	508098510015	Gear box components	1	
3	508098520004	Gear ring	1	
4	508098520003	Wheel ring	1	
5	508598510012	Motor components	1	
6	940900100011	Driving assembly	1	

Fig. 6 Cylinder

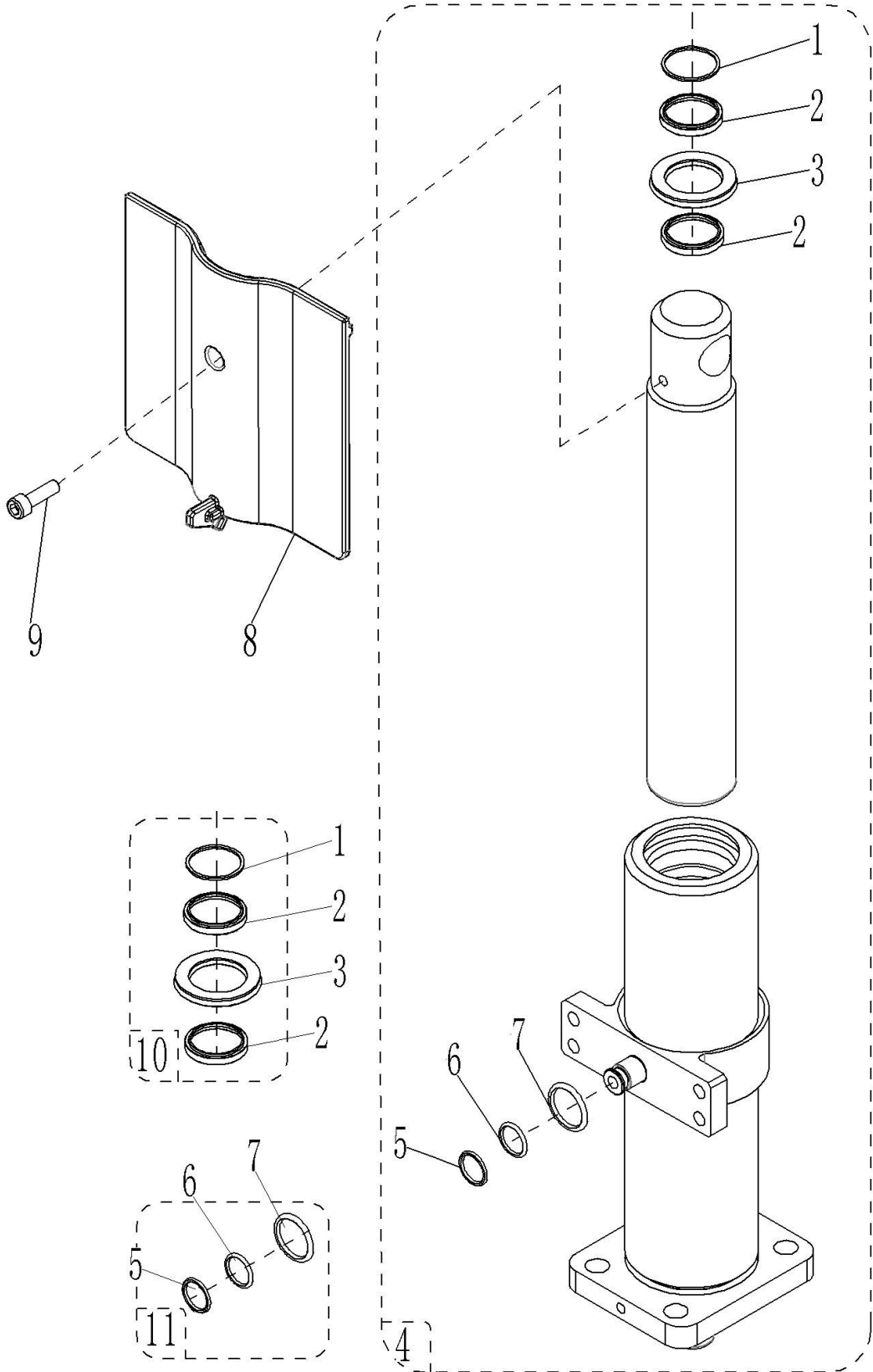

Fig. 6 Cylinder

No.	Art No.	Description	Qty.	Note
1	910800400003	Dust ring FC35x43x5	1	
2	910800500009	Support ring 35x40x10	2	
3	910800300013	Seal ring Y35x45x6	1	
4	508524010000	Cylinder components	1	
5	910800800003	Circlip 12.7x9.8x1.25	1	
6	910800100001	O ring -inner 9.5x1.8	1	
7	910800100098	O ring -inner 13.5x1.8	1	
8	508524020011	Cylinder cover	1	
9	910200200033	Screw GB70.1-M6x12-8.8	1	
10	508598510005	Sealing components	1	
11	508598510004	Sealing components	1	

Fig. 7 Power unit

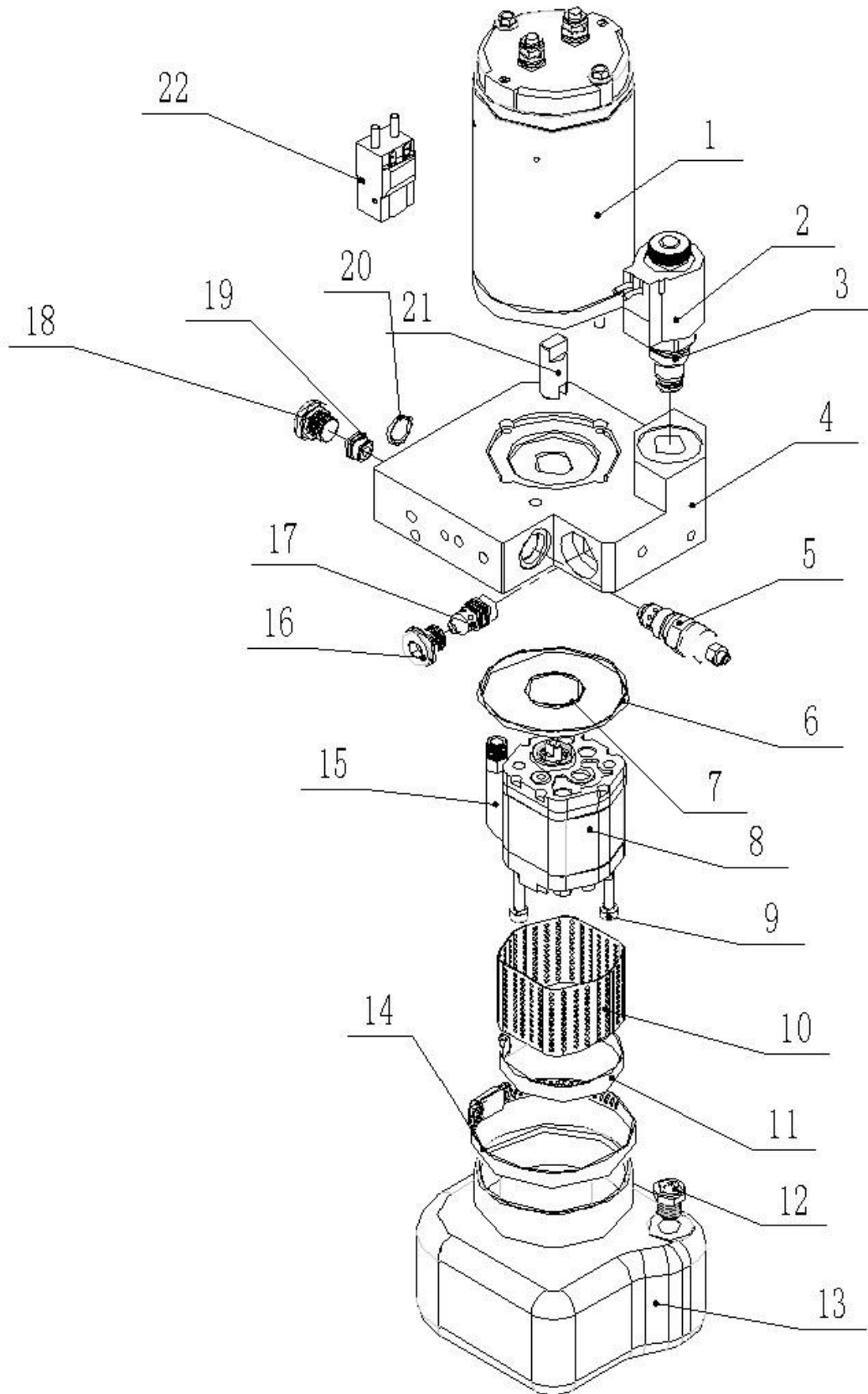

Fig. 7 Power Unit

No.	Art No.	Description	Qty.	Note
1	508598510007	DC Motor	1	MD48080AN
2	508598520001	48V DC coil	1	YC048DC
3	505698520054	Valve core	1	SCV
4	508598520002	CMB3 Valve block	1	CMB3-101-66E
5	504498510015	Overflow valve	1	RV-06
6	508598520003	O ring	1	67.95x2.62
7	910800100063	O ring -inner 21.2x1.8	1	21.2x1.8
8	508598510008	CBU gear pump	1	CBU-F1038
9	508598520004	Screw	2	M5x60
10	508598520005	Filter	1	59-30
11	508598520006	Clamp	1	KG02
12	508598510009	Cap	1	Z3/8
13	508598510010	Oil tank	1	0.4L-TP072A080-V
14	508598520007	Clamp	1	KG04
15	508598520008	Oil return hose	1	RU10-060
16	505698520043	Plug	1	SP-09
17	505698520041	Pressure compensation valve	1	RPCV-02-04
18	505698520037	Plug	1	SP-02
19	505698520038	Check valve	1	CV-03
20	910800100098	O ring -inner 13.5x1.8	1	13.5x1.8
21	508598520009	Coupler	1	DCP-312
22	508598520011	Relay	1	DK0148B

Fig. 8 Hydraulic components

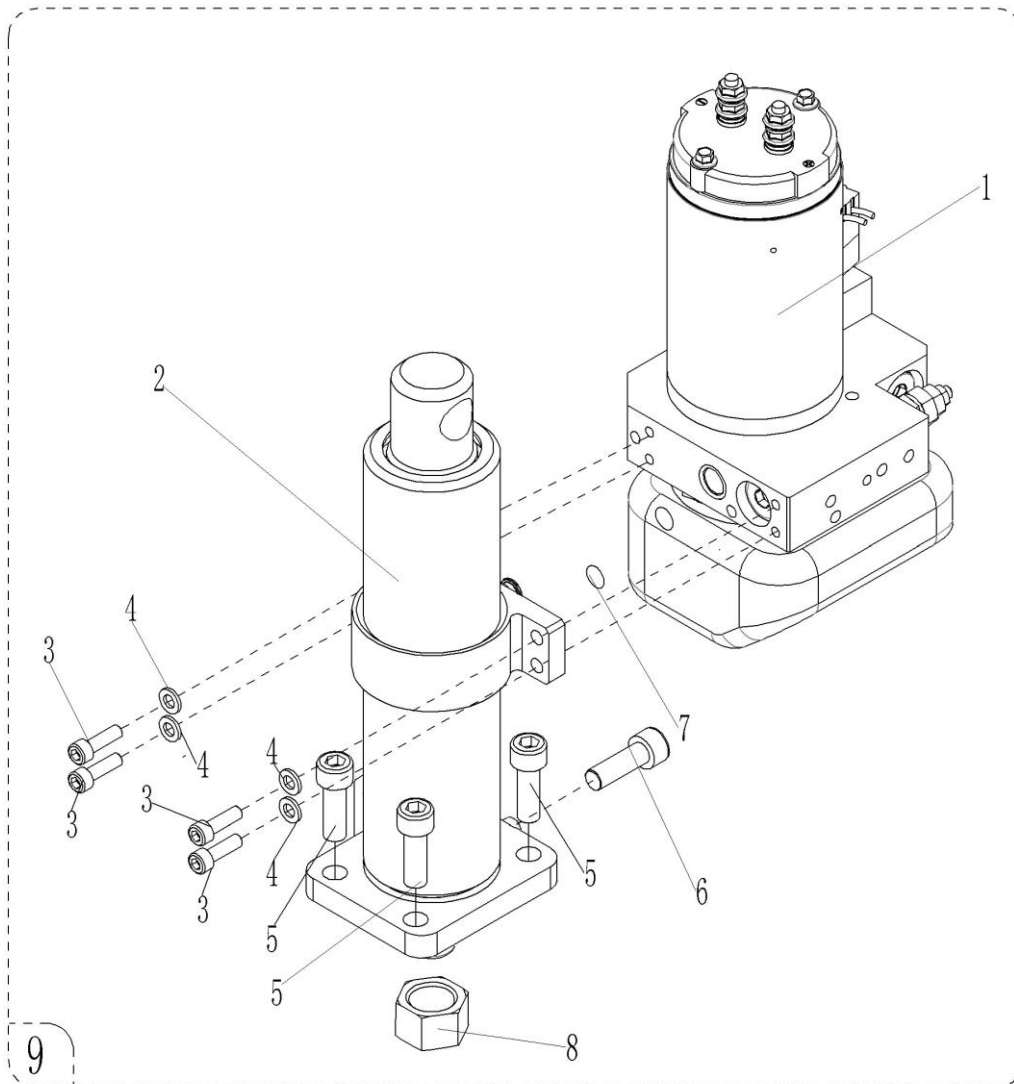

Fig. 8 Hydraulic Components

No.	Art No.	Description	Qty.	Note
1	950900100057	Hydraulic power unit 48V0.8KW0.38cc	1	
2	508524010000	Cylinder assembly	1	
3	910200200036	Screw GB70.1-M6x20-8.8	4	
4	910400100005	Washer GB97.1-6-200HV	7	
5	910200200077	Screw GB70.1-M10x30-8.8	4	
6	910200200045	Screw GB70.1-M6x6-8.8	1	
7	910800100098	O ring	1	13.5x1.8
8	910300400008	Nut GB6173-M20x1.5-05	1	
9	508524001000	Hydraulic components	1	

Fig. 9 Steering wheel components (with side rollers)

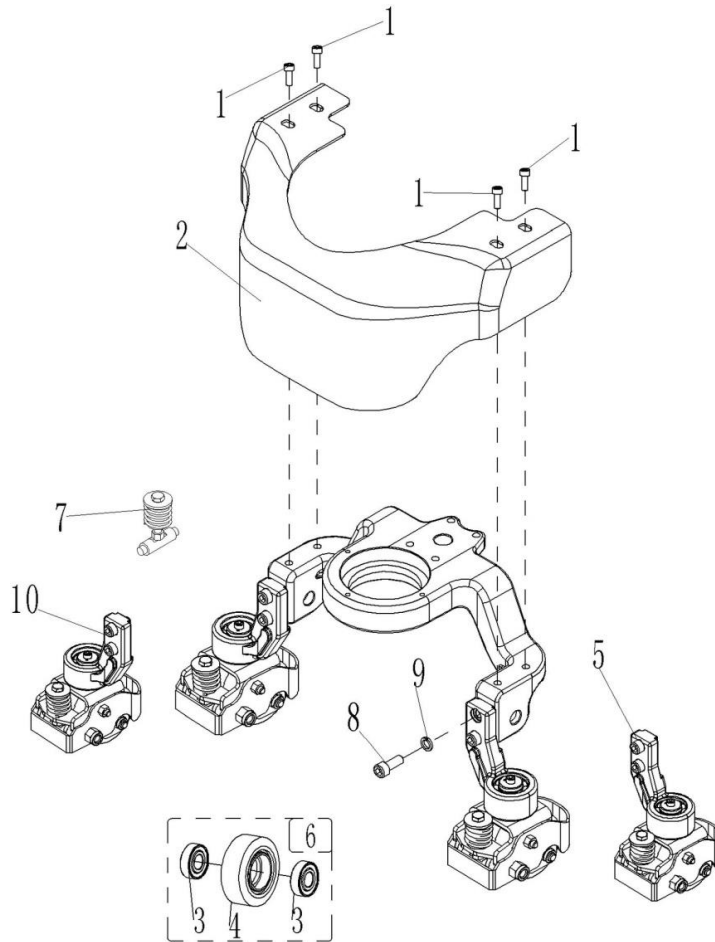

Fig. 9 Steering Wheel Components (with side rollers)

No.	Art No.	Description	Qty.	Note
1	941100100005	Screw M10x15-8.8	4	
2	508016520000	Apron (side roller)	1	Ground clearance 35mm
	508016520008			Ground clearance 45mm
3	910700200018	Bearing GB276-6203-2RS	4	
4	940300300017	Roller Φ 80x30(Steel core PU)	2	
5	508016510005	Side roller components Φ 80x30(PU/Right)	1	
6	502398510015	Roller components	2	
7	508098510047	Spring components	2	
8	910200200076	Screw GB70.1-M10x25-8.8	4	
9	910400100007	Washer GB97.1-10-200HV	4	
10	508016510002	Side roller components Φ 80x30(PU/Left)	1	

Fig. 10 Tiller head

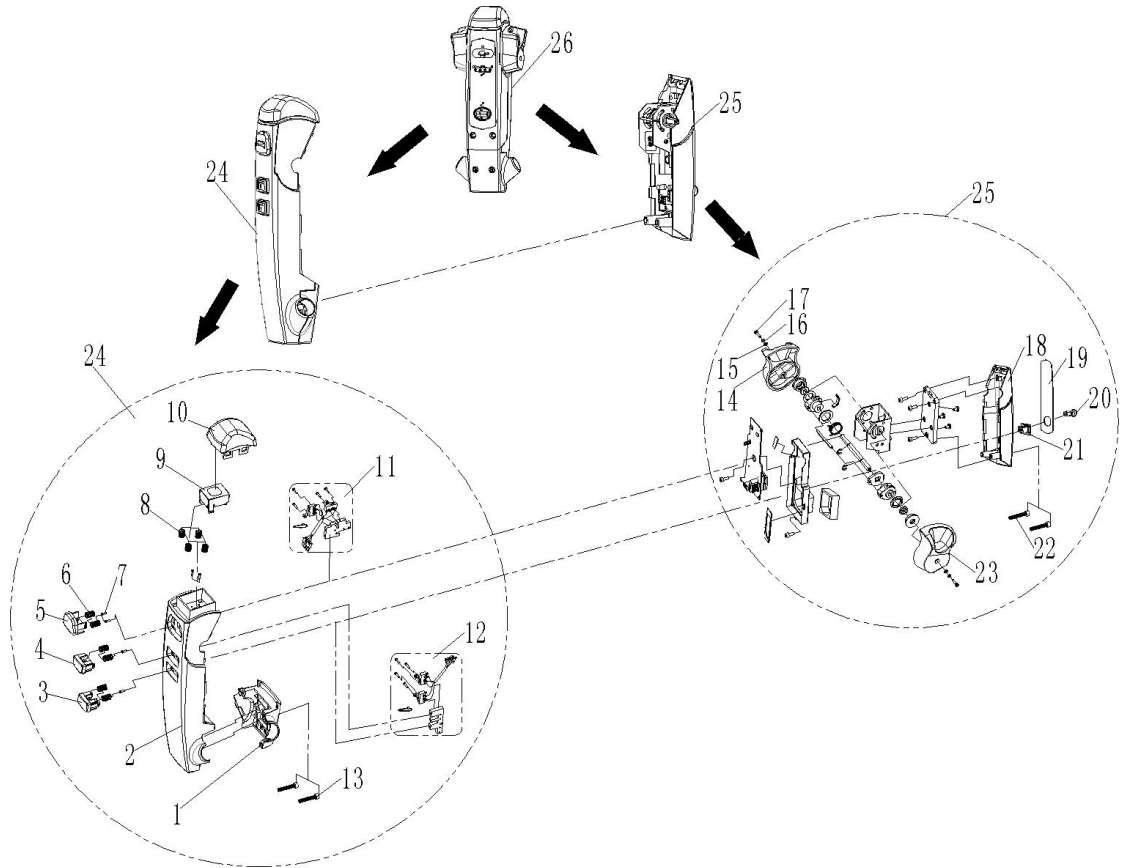

Fig. 10 Tiller Head

No.	Art No.	Description	Qty.	Note
1	508698520001	Tiller cover	1	
2	508698520002	Tiller front part	1	
3	508098520031	Lowering button	1	
4	508098520030	Lifting button	1	
5	508098520029	Horn button	1	
6	502311020022	Spring	6	Ø0.6*16mm
7	508698520003	Screw	8	ST2.2*13
8	502311020018	Spring	4	Ø0.8*11mm
9	508098520019	Belly button transition button	1	
10	508098520018	Belly button	1	

11	508698510005	Horn micro switch assembly	1	Z211
12	508698510006	Lifting micro switch assembly	1	Z212
13	910200200028	Screw GB70.1-M5x40-8.8	2	M5*40
14	508098520020	Right driving knob	1	N200
15	910400100002	Washer GB97.1-3-200HV	2	Ø3
16	910400500002	Spring Washer GB93-3	2	Ø3
17	508698520004	Bolt	2	M3*14
18	508698520005	Tiller back part	1	N200
19	508698520006	Pin-code panel sticker	1	N200
20	508698520000	Key	2	N200
21	508698520007	Key base	1	N200
22	910200200159	Screw (black) GB70.1-M5x50-8.8	2	M5*50
23	508098520014	Left driving knob	1	N200
24	508698510004	Back part assembly	1	Z400-13/26C-6
25	508698510007	Front part assembly	1	Z401-1
26	922100100034	Tiller	1	N200(26C-6)

Fig. 11 Tiller arm components

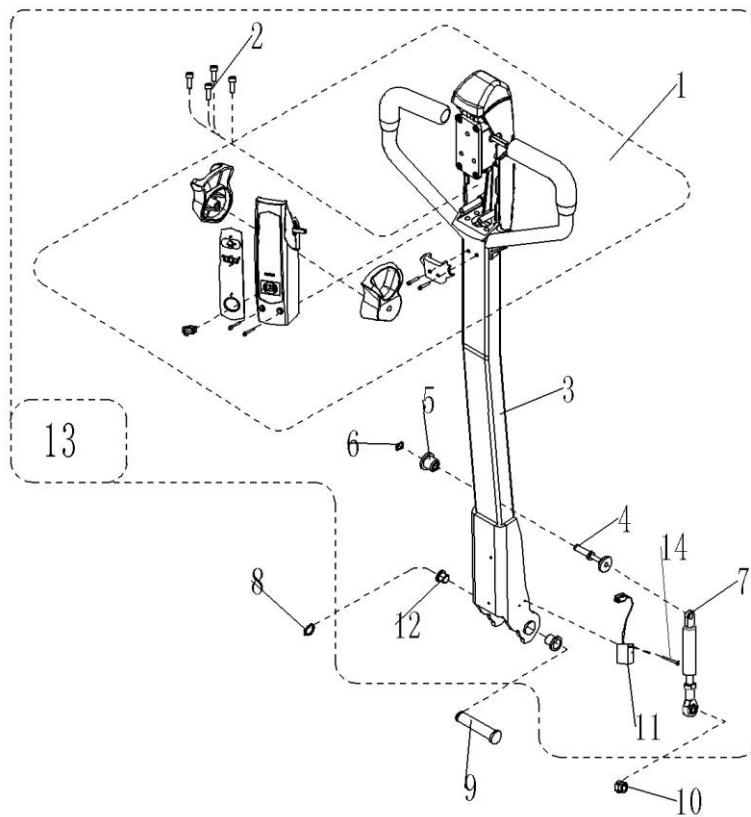

Fig. 11 Tiller Arm Components

No.	Art No.	Description	Qty.	Note
1	922100100034	Tiller N200(26C-6)	1	
2	910200200040	Screw GB70.1-M6x35-8.8	4	
3	508011010000	Tiller arm welding	1	
4	508011010002	Fixing axle welding	1	
5	508011020005	Fixing base	1	
6	910401300001	Circlip GB894.1-8	1	
7	508011010001	Air spring (D245)	1	
8	910401300006	Circlip GB894.1-15	1	
9	508011020004	Axle Φ 15x70	1	
10	910200200057	Screw GB70.1-M8x20-8.8	1	
11	505633510002	Proximity switch NBN5-F7-E2(800mm)	1	
12	940500200001	Bushing (With shoulder) Φ 15x Φ 17x9-SF-1	2	
13	508611001000	Tiller control assembly	1	

Fig. 12 Truck components

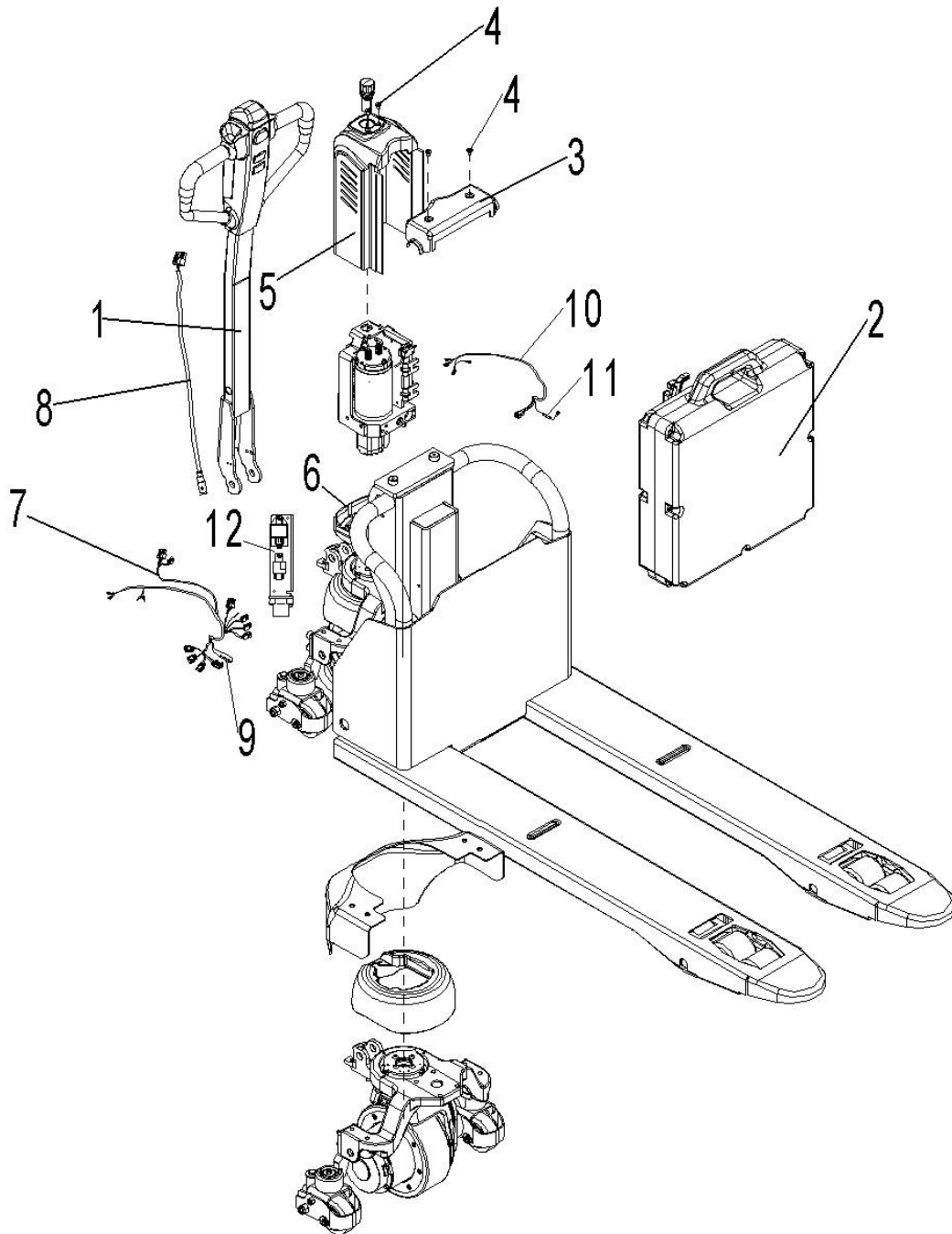

Fig. 12 Truck Components

No.	Art No.	Description	Qty.	Note
1	508611001000	Tiller assembly	1	
2	502137001000	Power supply assembly	1	20Ah
3	508638520000	Top cover	1	
4	910200400015	Screw GB70.3-M6x10-8.8	4	
5	508524020010	Motor protective cover	1	
6	508524020012	Electrical cover base	1	
7	508533010009	Main control wiring harness (CURTIS1226BL-4153+ZD+JS)	1	Standard
8	508533010001	Tiller control wiring harness	1	
9	920100200002	Fuse 10A	1	
10	508633010006	Supporting control wiring harness 1	1	
11	920100300003	Fuse tube 6A	1	
12	508633010010	Power supply control components	1	

Fig.13 Power supply assembly

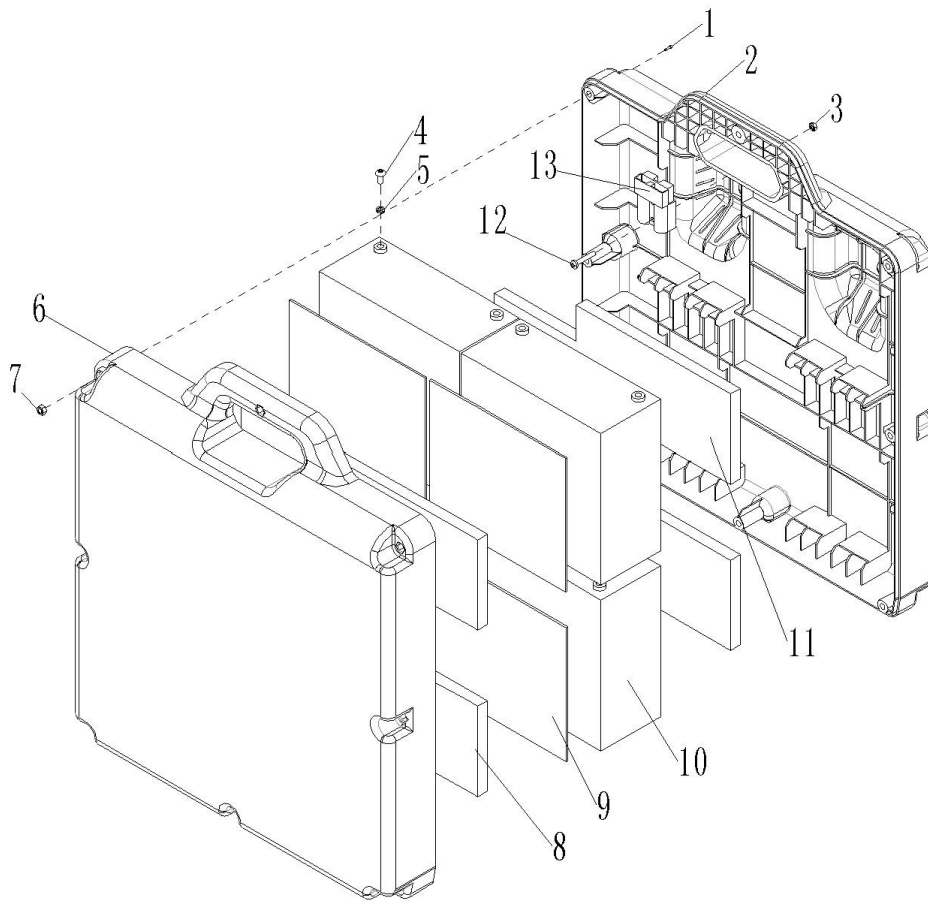

Fig. 13 Power supply assembly

No.	Art No.	Description	Qty.	Note
1	910200200023	Screw GB70.1-M5x16-8.8	8	
2	502137020000	Battery box (back)	1	
3	910300100003	Nut GB6170-M4-10	2	
4	910200300011	Screw GB70.2-M5x10-8.8	8	
5	910400500004	Spring Washer GB93-5	8	
6	502137020001	Battery box (front)	1	
7	910300100004	Nut GB6170-M5-10	8	
8	508633020002	EVA sponge 2	3	
9	508633020001	EVA sponge 1	4	
10	920600100024	Battery 12V20Ah2HR	4	
11	508633020003	EVA sponge 3	1	
12	910200500027	Screw GB818-M4x25-4.8	2	
13	920400100003	Plug REMA78184-00	1	

Fig. 14 Controller components

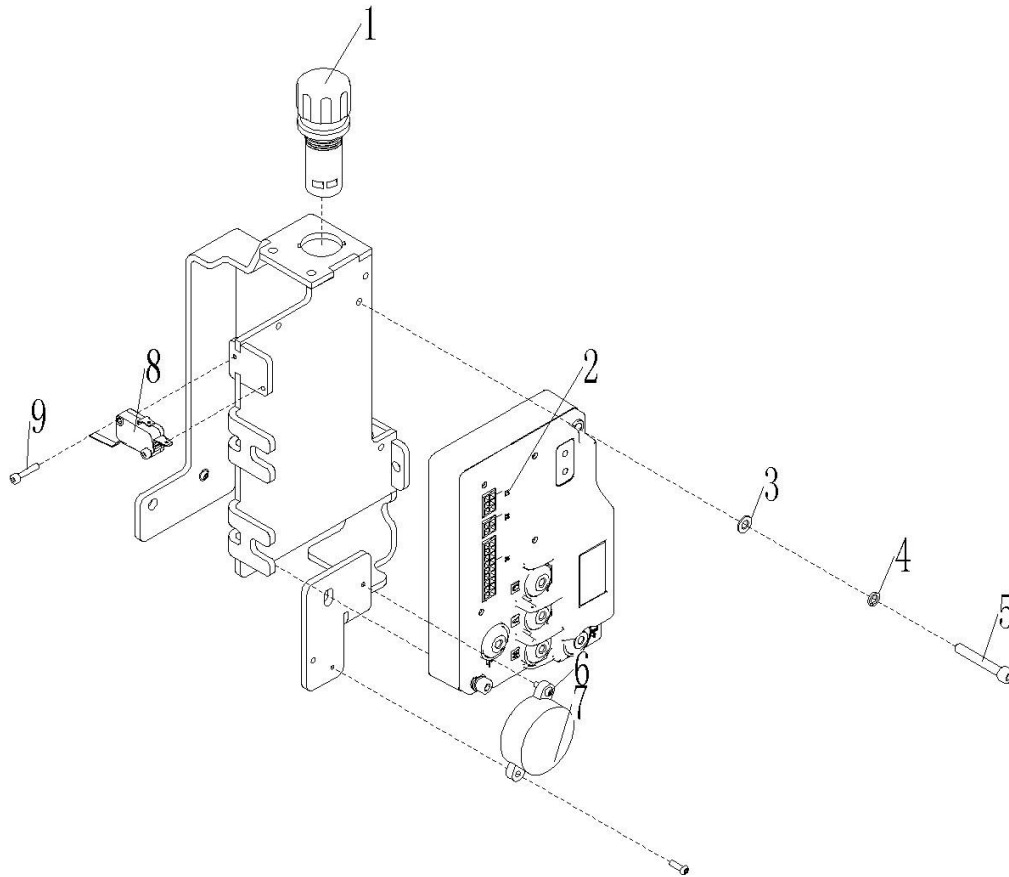

Fig. 14 Controller Components

No.	Art No.	Description	Qty.	Note
1	920200100015	Emergency button CE3T-10R-02	1	
2	921400100093	Controller 1226BL-4153	1	
3	910400100004	Washer GB97.1-5-200HV	2	Washer GB97.1-5-200HV-A-c1B
4	910400500004	Spring Washer GB93-5	2	Spring Washer GB93-5-c1B
5	910200200027	Screw GB70.1-M5x35-8.8	2	Screw GB70.1-M5x35-8.8-c1B
6	910200500010	Screw GB818-M3x8-4.8	2	Screw GB818-M3x8-4.8-Z-c1B
7	920500100004	Horn HYD-4216W-48V	1	
8	920200300015	Micro switch BH-KW9-10305A	1	
9	910200200004	Screw GB70.1-M3x16-8.8	2	Screw GB70.1-M3x16-8.8-c1B

Fig. 15 Power supply control components

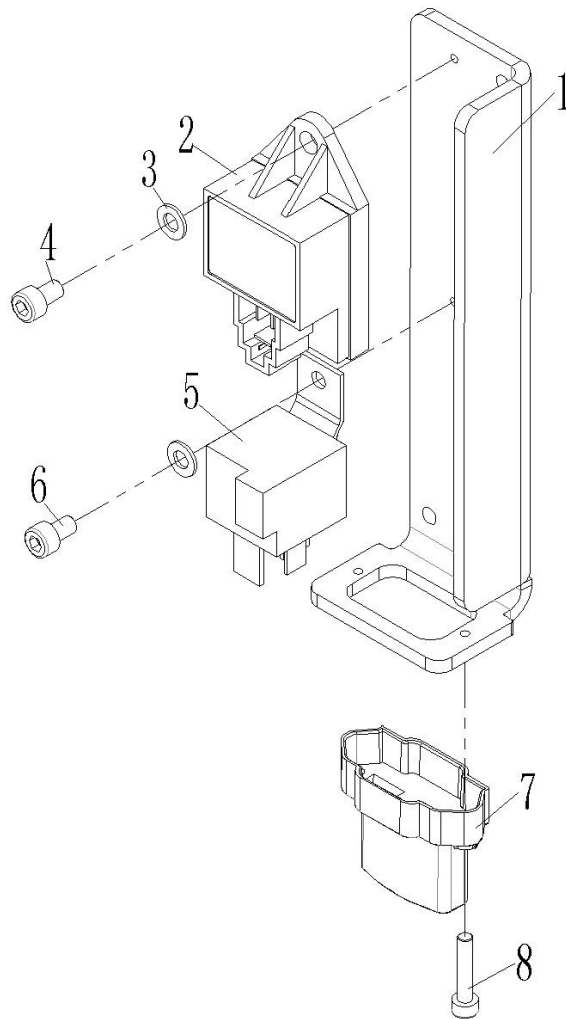

Fig. 15 Power Supply Control Components

No.	Art No.	Description	Qty.	Note
1	508638520020	Mounting plate	1	
2	921900100013	Convertor DC30-72V 转 48V	1	
3	910400500003	Spring Washer GB93-4	2	
4	910200200013	Screw GB70.1-M4x10-8.8	1	
5	920800100008	Relay DC48V-JD2919	1	80A
6	910200500020	Screw GB818-M4x6-4.8	1	
7	920100400011	Fuse seat NL-ATM-B	1	
8	910200200004	Screw GB70.1-M3x16-8.8	2	

Fig. 16 Charger

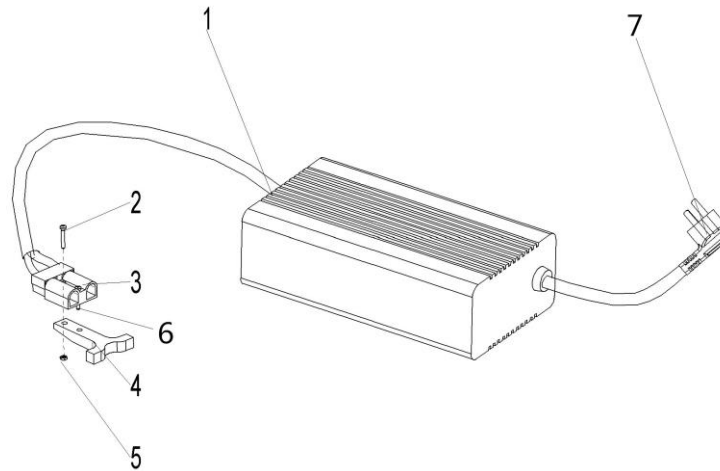

Fig. 16 Charger

No.	Art No.	Description	Qty.	Note
1	921000200127	Charger	1	
2	910200500027	Screw GB818-M4x25-4.8	1	
3	920400100003	Plug REMA78184-00	1	
4	920400100010	Plug REMAG78295-05	1	
5	910300500001	Nut GB889.1-M4-10	2	
6	910200500028	Screw GB818-M4x30-4.8	1	
7	921500200021	Charging cable 3x0.75(Asia)	1	
	921500200027	Charging cable 3x0.75(ENG)	1	
	921500200023	Charging cable 3x0.75(US)	1	
	921500200022	Charging cable 3x0.75(EU)	1	
	921500200024	Charging cable 3x0.75(AUS)	1	
	921500200025	Charging cable 3x0.75(ITY)	1	
	921500200026	Charging cable 3x0.75(Sweden)	1	
8	502102036501	48V3ACharger(Asia MK)	1	
	502102036502	48V3ACharger(EU MK)	1	
	502102036503	48V3ACharger(US MK)	1	
	502102036504	48V3ACharger(AUS MK)	1	
	502102036505	48V3ACharger(ITY MK)	1	
	502102036506	48V3ACharger(Sweden MK)	1	
	502102036507	48V3ACharger(ENG MK)	1	

Fig. 17 Wiring harness

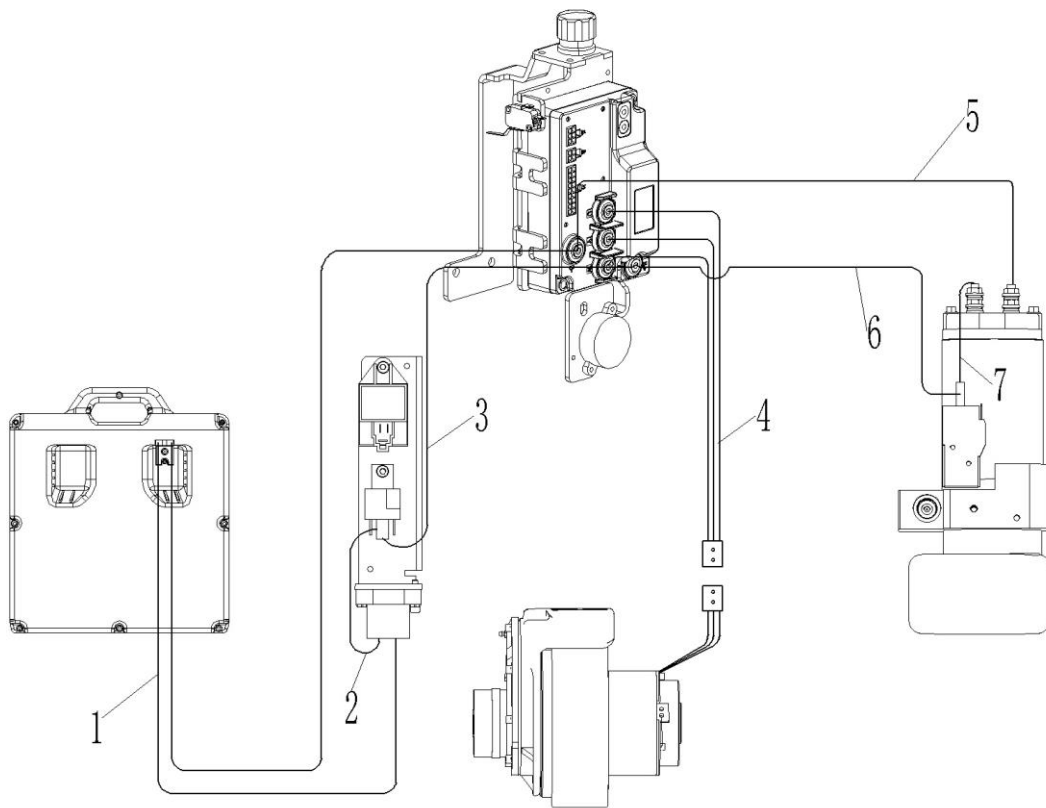

Fig. 17 Wiring Harness

No.	Art No.	Description	Qty.	Note
1	508633010005	Main plug wiring harness	1	
2	508633010007	Mai power supply B+ wiring harness	1	
3	508633010009	Supporting control wiring harness 2	1	
4	508533010007	Motor main wiring harness	1	
5	508533010005	Controller B-iring harness	1	
6	508533010004	Controller B+iring harness	1	
7	508533010006	Pump motor B+iring harness	1	

Fig. 18 Sticker (EU)

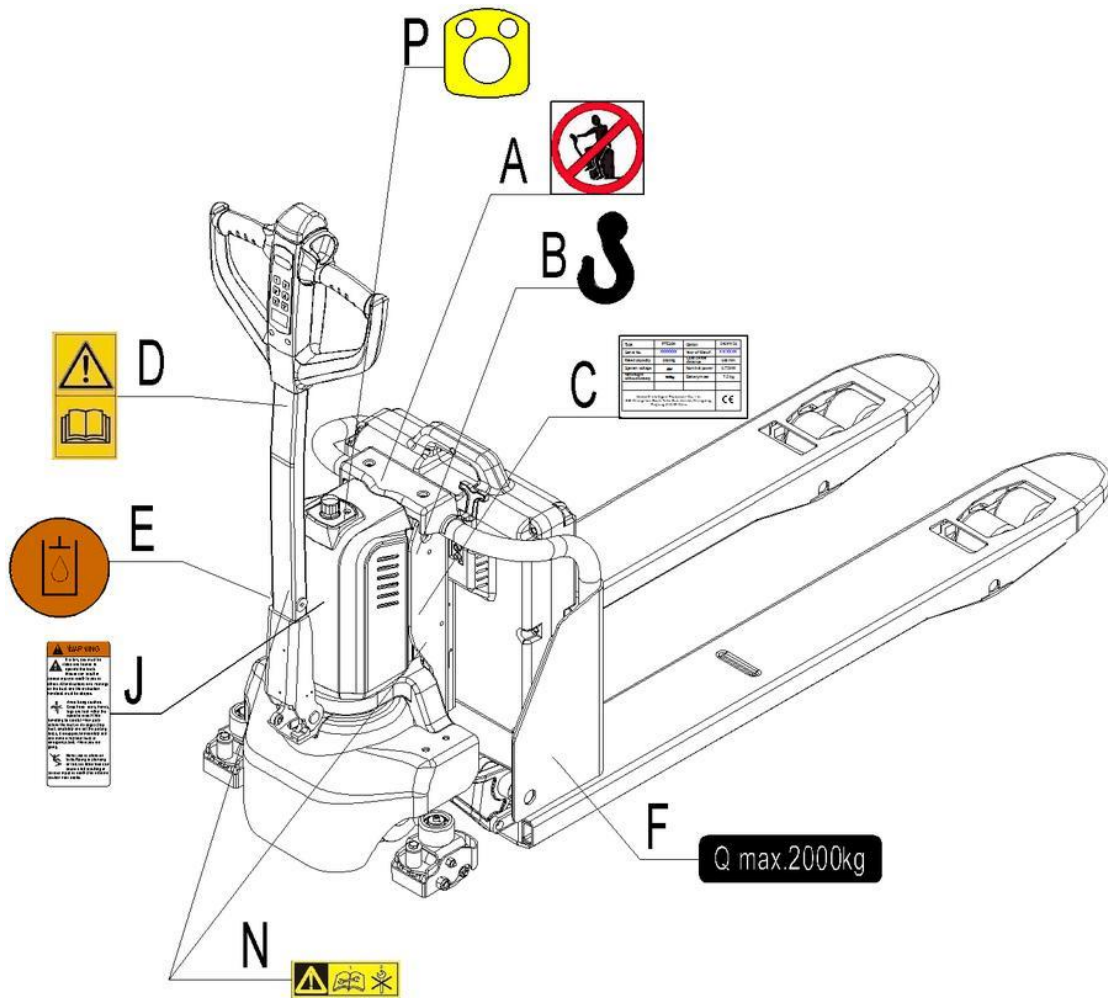

Fig. 18 Sticker (EU)

No.	Art No.	Description	Qty.	Note
A	941200100003	"No passengers" decal	1	
B	941200300001	Crane hook label	1	
C	508647520000	CE sticker (PTE20B540x1150)	1	
	508647520001	CE sticker (PTE20B685x1150)	1	
D	941200300002	Sticker to read and follow these instructions	1	
E	941200300003	Filling sticker	1	
F	941200200023	Capacity sticker	2	
J	941200100009	Warning sticker	1	
N	508047020004	Sticker to read and follow service manual	2	
P	508547020000	Emergency button sticker	1	

Fig. 19 Sticker (US)

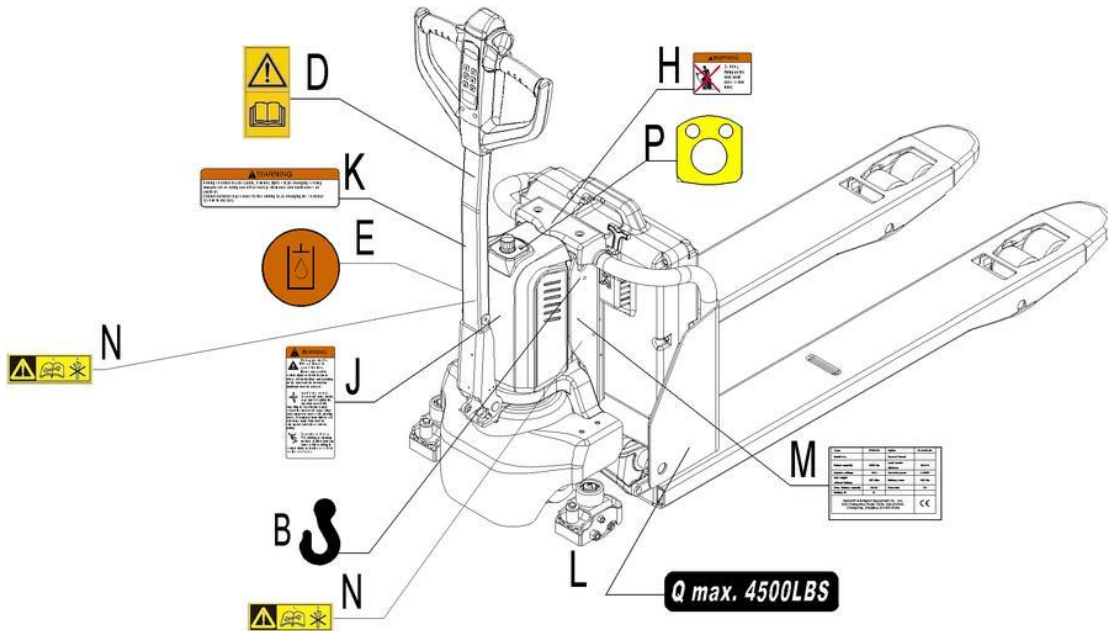

Fig. 19 Sticker (US)

No.	Art No.	Description	Qty.	Note
B	941200300001	Crane hook label	1	
D	941200300002	Sticker to read and follow these instructions	1	
E	941200300003	Filling sticker	1	
H	941200100011	"No passengers" decal	1	
J	941200100009	Warning sticker	1	
K	941200100010	Warning sticker	1	
L	941200200050	Capacity sticker (4500LBS)	2	
M	508647520002	CE sticker (PTE20B21.3x45.3)	1	
	508647520003	CE sticker (PTE20B27x45.3)	1	
N	508047020004	Sticker to read and follow service manual	2	
P	508547020000	Emergency button sticker	1	

Easy worn parts list

No.	Art No.	Description	Qty.	Fig. /Position	Note
1	940500100097	Bushing Φ 24.6x Φ 29x25	4	Fig. 1/4	With grease storage holes
2	940500100083	Bushing Φ 16x Φ 18x15	8	Fig. 1/9	With grease storage holes
3	508698510000	Push rod components (1150)	2	Fig. 1/21	1150
4	508698510001	Rock arm components	1	Fig. 1/22	
5	508698510002	Push rod kits (1150)	2	Fig. 1/23	1150
6	508098510004	Push rod fork components	2	Fig. 1/24	
7	940500100097	Bushing Φ 24.6x Φ 29x25	4	Fig. 2/4	With grease storage holes
8	940500100083	Bushing Φ 16x Φ 18x15	8	Fig. 2/9	With grease storage holes
9	508698510003	Rock arm components (685)	1	Fig. 2/22	
10	508698510000	Push rod components (1150)	2	Fig. 2/21	1150
11	508698510002	Push rod kits (1150)	2	Fig. 2/23	1150
12	508098510004	Push rod fork components	2	Fig. 2/24	
13	910700200019	Bearing GB276-6204-2RS	8/4(Tandem/Single)	Fig. 3/4	
14	940300300005	Roller Φ 80x70(Steel core PU)	4(Tandem)	Fig. 3/5	
15	940300300023	Roller Φ 80x93(Steel core PU)	2(Single)	Fig. 3/10	
16	940500200038	Bushing (With shoulder) Φ 18x Φ 20x12	4 (Tandem)	Fig. 3/11	With grease storage holes
17	940500100088	Bushing Φ 20x Φ 22x12	4	Fig. 3/12	With grease storage holes
18	502398510014	Wheel set kits (Single)	2	Fig. 3/13	
19	502398510003	Entry roller kits	2	Fig. 3/14	
20	502398510020	Roller kits (Tandem)	2	Fig. 3/15	
21	502398510017	Roller kits (Single)	2	Fig. 3/16	
22	502398510019	Frame of roller components (75mm)	2	Fig. 3/17	Low profile
23	502398510002	Wheel set kits (Tandem)	2	Fig. 3/18	

24	910700200058	Bearing GB276-6013-2RS	1	Fig. 4/4	
25	910700600044	Bearing GB297-32913	1	Fig. 4/6	
26	910800800003	Circlip 12.7x9.8x1.25	1	Fig. 6/5	
27	910800100001	O ring	1	Fig. 6/6	9.5x1.8
28	910800100098	O ring	1	Fig. 6/7	13.5x1.8
29	508598510005	Sealing components	1	Fig. 6/10	
30	508598510004	Sealing components	1	Fig. 6/11	
31	508598520003	O ring	1	Fig. 7/6	67.95x2.62
32	910800100063	O ring -inner 21.2x1.8	1	Fig. 7/7	21.2x1.8
33	910800100098	O ring -inner 13.5x1.8	1	Fig. 7/20	13.5x1.8
34	910800100098	O ring	1	Fig. 8/7	13.5x1.8
35	910700200018	Bearing GB276-6203-2RS	2	Fig. 9/3	
36	940300300017	Roller Φ 80x30(Steel core PU)	1	Fig. 9/4	
37	508016510000	Side roller components Φ 80x30(PU)	1	Fig. 9/5	
38	502398510015	Roller components	1	Fig. 9/6	
39	502398510016	Spring components	1	Fig. 9/7	
40	508016510002	Side roller components Φ 80x30(PU/Left)	1	Fig. 9/10	
41	940500200001	Bushing (With shoulder) Φ 15x Φ 17x9	2	Fig. 11/12	
42	920100200002	Fuse 10A	1	Fig. 12/9	
43	920100200009	Fuse 70A-1	1	Fig. 13/2	NL-ATM70DC58V
44	920100300003	Fuse tube 6A	1	Fig. 12/11	